

REVERSIBLE GEARBOX WITH PARALLEL GEARS ASYNCHRONOUS MOTOR

APPLICATIONS :

- Automatic barriers
- Agitator
- Labelling machines

TECHNICAL FEATURES :

- Asynchronous motor
- Greased lubricated
- Thermal cut out
- 2 direction of rotation
- Class B insulation
- IP44 protection
- S1 service class
- Working Temperature : -20°C to +85°C

OPTIONS AVAILABLE ON DEMAND :

- Inrush or lack of current brake (24V or 230V with diode rectifier) with or without manual unlocking
- Voltages and frequencies on request
- Class F insulation
- IP55 protection
- Output shaft according to specifications

COMPLY WITH STANDARDS :

- EN 60335-1
- EN 60034-1

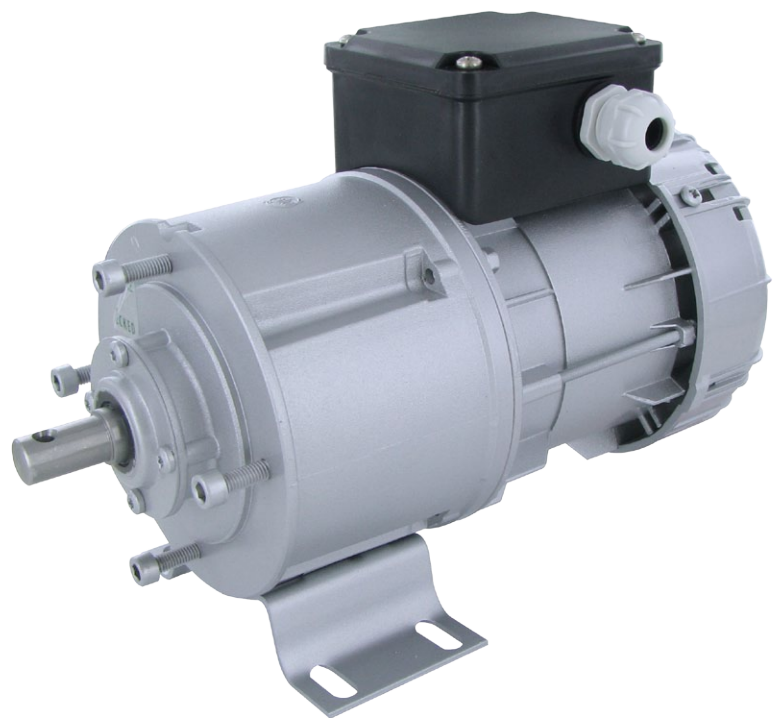

Terminal box positions

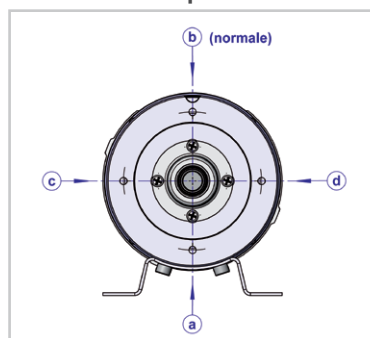

Shaft with keyway on demand

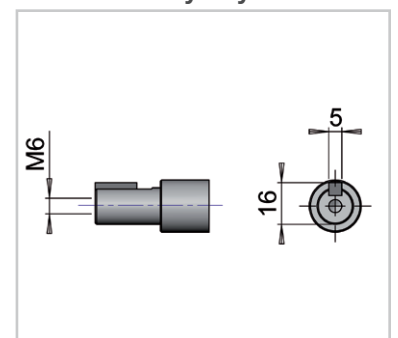

DIMENSIONS

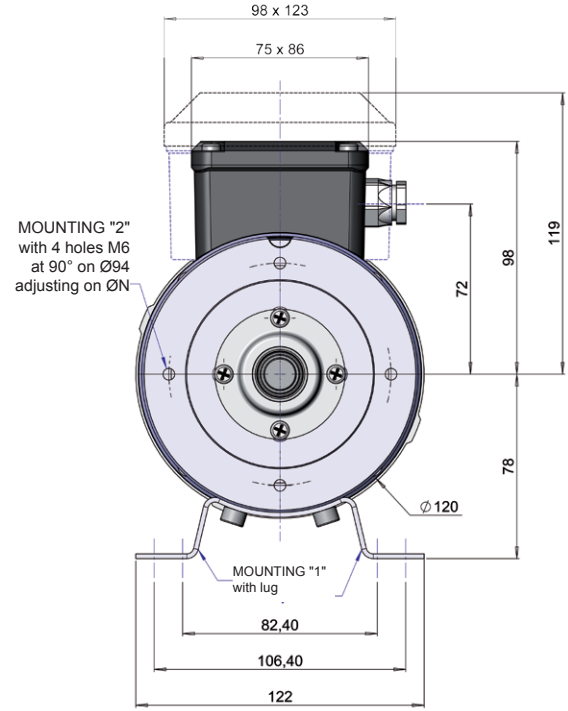
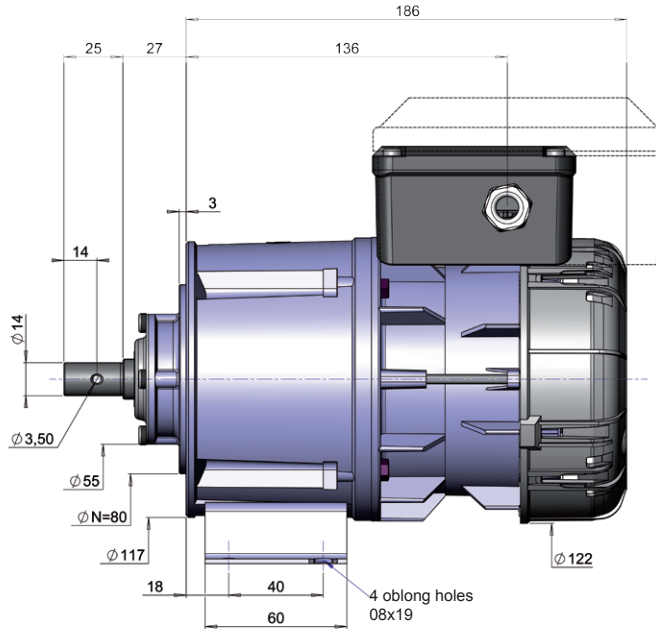

TECHNICAL FEATURES

Designation and Motor Type	GEARBOX						MOTOR									Weight (kg)	
	Gearbox speed (RPM)	Nominal torque (Nm)	Startup torque (Nm)	Maximum radial load** (N)	Maximum axial load (N)	Gearbox ratio	Output power (watts)	Motor torque (Ncm)	Motor speed (RPM)	Current under 230v (A)	Ia/In	Cd/Cn	Cos φ	Service class	Capacitor (µF)		
Single phase versions	R1C 425 H B	2,3	35*	30	1000	1050	1/547	40	28,3	1350	0,55	1,34	0,85	0,99	S1	4	3
	R1C 425 H B	3,5	30*	26	1000	1050	1/390	40	28,3	1350	0,55	1,34	0,85	0,99	S1	4	3
	R1C 225 H B	4,5	35*	49	1000	1050	1/547	38	13,4	2700	0,47	1,67	1,4	0,99	S1	4	3
	R1C 225 HB	7	30*	42	1000	1050	1/390	38	13,4	2700	0,47	1,67	1,4	0,99	S1	4	3
	R1C 425 H B	10,5	15*	13	920	800	1/134	40	28,3	1350	0,55	1,34	0,85	0,99	S1	4	3
	R1C 225 H B	15	15*	21	820	700	1/184	38	13,4	2700	0,47	1,67	1,4	0,99	S1	4	3
	R1C 225 H B	21	12	17	740	600	1/134	38	13,4	2700	0,47	1,67	1,4	0,99	S1	4	3
	R1C 225 H B	30	8,7	12	640	500	1/96	38	13,4	2700	0,47	1,67	1,4	0,99	S1	4	3
	R1C 225 H B	39	6,6	9	600	460	1/72	38	13,4	2700	0,47	1,67	1,4	0,99	S1	4	3
	R1C 225 H B	48	5,4	8	560	420	1/59	38	13,4	2700	0,47	1,67	1,4	0,99	S1	4	3
	R1C 225 HB	65	4,1	6	500	360	1/45	38	13,4	2700	0,47	1,67	1,4	0,99	S1	4	3
	R1C 425 H B	100	2,2*	2	440	300	1/14	40	28,3	1350	0,55	1,34	0,85	0,99	S1	4	3
	R1C 225 H B	125	2,2	3	410	270	1/22	38	13,4	2700	0,47	1,67	1,4	0,99	S1	4	3
	R1C 225 H B	200	1,4	2	350	230	1/14	38	13,4	2700	0,47	1,67	1,4	0,99	S1	4	3
Three phase versions	R3 425 HB	2,3	35	67	1000	1050	1/547	40	27,3	1400	0,41	2	1,9	0,65	S1	-	3
	R3 425 H B	3,5	30*	57	1000	1050	1/390	40	27,3	1400	0,41	2	1,9	0,65	S1	-	3
	R3 225 H B	4,5	35*	34	1000	1050	1/547	44	15,5	2700	0,29	2,45	0,97	0,82	S1	-	3
	R3 225 H B	7	30*	29	1000	1050	1/390	44	15,5	2700	0,29	2,45	0,97	0,82	S1	-	3
	R3 425 HB	10,5	15*	29	920	800	1/134	40	27,3	1400	0,41	2	1,9	0,65	S1	-	3
	R3 225 H B	15	15*	15	820	700	1/184	44	15,5	2700	0,29	2,45	0,97	0,82	S1	-	3
	R3 225 H B	21	14	14	740	600	1/134	44	15,5	2700	0,29	2,45	0,97	0,82	S1	-	3
	R3 225 H B	30	10	10	640	500	1/96	44	15,5	2700	0,29	2,45	0,97	0,82	S1	-	3
	R3 225 H B	39	7,6	7	600	460	1/72	44	15,5	2700	0,29	2,45	0,97	0,82	S1	-	3
	R3 225 H B	48	6,2	6	560	420	1/59	44	15,5	2700	0,29	2,45	0,97	0,82	S1	-	3
	R3 225 H B	65	4,7	5	500	360	1/45	44	15,5	2700	0,29	2,45	0,97	0,82	S1	-	3
	R3 425 H B	100	2,2*	4	440	300	1/14	40	27,3	1400	0,41	2	1,9	0,65	S1	-	3
	R3 225 H B	125	2,6	3	410	270	1/22	44	15,5	2700	0,29	2,45	0,97	0,82	S1	-	3
	R3 225 H B	200	1,7	2	350	230	1/14	44	15,5	2700	0,29	2,45	0,97	0,82	S1	-	3

* : acceptable torque not exceed

** : applied on the middle of the shaft end

